

1997 Pontiac Grand Prix GT

SLIPS, HARSH UPSHIFT OR GARAGE SHIFTS, LAUNCH SHUDDERS, FLARES, ERRATIC SHIFTS AND INTERMITTENT CONCERNS, DTC P1811 OR P0748 SET (REPLACE PRESSURE CONTROL SOLENOID VALVE ASSEMBLY)

BULLETIN CONTENT



Service Bulletin

File In Section: 07 - Transmission/Transaxle

Bulletin No.: 00-07-30-002B

Date: July, 2002



TECHNICAL

Subject: Slips, Harsh Upshift or Garage Shifts, Launch Shudders, Flares, Erratic Shifts and Intermittent Concerns, DTC P1811 or P0748 Set (Replace Pressure Control Solenoid Valve Assembly)

Models: 1997–1999 Buick Riviera
1997–2002 Buick Park Avenue
1998–2002 Buick LeSabre
1999–2002 Buick Regal
2000–2002 Buick Century
2002 Buick Rendezvous
1997–2001 Chevrolet Lumina
1997–2002 Chevrolet Monte Carlo
1999–2002 Chevrolet Venture
2000–2002 Chevrolet Impala
1997–1999 Oldsmobile Eighty Eight
1997–2002 Oldsmobile Silhouette
1998–2002 Oldsmobile Intrigue
2001–2002 Oldsmobile Aurora (3.5L)
1997–2002 Pontiac Bonneville, Grand Prix
1999–2002 Pontiac Transport/Montana
2001–2002 Pontiac Aztek
with Hydra-Matic 4T65-E (RPOs MN3, MN7, M15, M76)

This bulletin is being revised to add additional models and model years. Please discard Corporate Bulletin Number 00-07-30-002A (Section 07 — Transmission/Transaxle).

Condition

Some owners of the above vehicles with a Hydra-Matic 4T65-E transaxle may comment on harsh upshifts or harsh garage shifts, soft shifts, shudders on hard acceleration, or shifts erratic. These conditions may appear intermittently or set a DTC P1811 or P0748. During diagnosis, a low or high line pressure (actual versus desired) may be observed.

G00137553

Fig. 1: Page 1 of Bulletin

Microsoft

Thursday, March 20, 2014 2:19:36 AM

Page 1

© 2006 Mitchell Repair Information Company, LLC.

1997 Pontiac Grand Prix GT

SLIPS, HARSH UPSHIFT OR GARAGE SHIFTS, LAUNCH SHUDDERS, FLARES, ERRATIC SHIFTS AND INTERMITTENT CONCERNS, DTC P1811 OR P0748 SET (REPLACE PRESSURE CONTROL SOLENOID VALVE ASSEMBLY)

Page 2

July, 2002

Bulletin No.: 00-07-30-002B

Cause

The above condition may be due to any one of the following which may affect line pressure output:

- Sediment inside the pressure control (PC) solenoid valve, causing the PC solenoid valve to mechanically bind.
- Sediment in the valve body, causing the torque signal regulator valve to stick.
- Incorrect transaxle oil level.

Correction

Important: Any of the above conditions may be intermittent, therefore, this test should be performed at least three times.

Refer to the Line Pressure Check Procedure in SI, along with the Line Pressure Specification Table below, to determine if actual versus desired pressures are within the values specified. The Scan Tool is only able to control the PC solenoid valve in PARK and NEUTRAL with the vehicle stopped. This protects the clutches from extremely high or low pressures in DRIVE or REVERSE ranges.

Refer to the Line Pressure Specification Table below. The pressures in the table assume a temperature of 70°C. The pressure will vary with a change in temperature.

Line Pressure Specification Table

Pressure Control Solenoid Valve Current	Approximate Line Pressure*	
	Metric	English
0 amp	1675–2137 kPa	243–310 psi
0.1 amp	1662–2124 kPa	241–308 psi
0.2 amp	1613–2103 kPa	234–305 psi
0.3 amp	1551–2068 kPa	225–300 psi
0.4 amp	1448–1986 kPa	210–288 psi
0.5 amp	1310–1903 kPa	190–276 psi
0.6 amp	1172–1751 kPa	170–254 psi
0.7 amp	1000–1531 kPa	145–222 psi
0.8 amp	793–1227 kPa	115–178 psi
0.9 amp	565–896 kPa	82–130 psi
1 amp	469–641 kPa	68–93 psi
1.1 amp	448–552 kPa	65–80 psi

*Approximate Line Pressure is measured at an engine speed of 1400 RPM.

If the actual versus desired pressures are not within the values specified, clean the valve body and replace the PC solenoid valve, if necessary.

Check the PC solenoid valve actual versus desired pressures to verify the new PC solenoid valve is responding correctly.

Refer to the Automatic Transaxle Section of the Service Manual for the proper repair procedure.

G00137554

Fig. 2: Page 2 of bulletin

SLIPS, HARSH UPSHIFT OR GARAGE SHIFTS, LAUNCH SHUDDERS, FLARES, ERRATIC SHIFTS AND INTERMITTENT CONCERNS, DTC P1811 OR P0748 SET (REPLACE PRESSURE CONTROL SOLENOID VALVE ASSEMBLY)

Line Pressure Check Procedure

Tools Required

J 21867 Universal Pressure Gauge Set

Important: Before performing a line pressure check, verify that the pressure control (PC) solenoid valve is receiving the correct electrical signal from the PCM.

1. Install a Scan Tool.

Caution: *Keep the brakes applied at all times in order to prevent unexpected vehicle motion. Personal injury may result if the vehicle moves unexpectedly.*

2. Start the engine and set the parking brake.
3. Check for a stored Diagnostic Trouble Code (DTC).
4. Repair the vehicle, if necessary.
5. Check the fluid level. Refer to the Transmission Fluid Checking Procedure.
6. Check the manual linkage for proper adjustment.

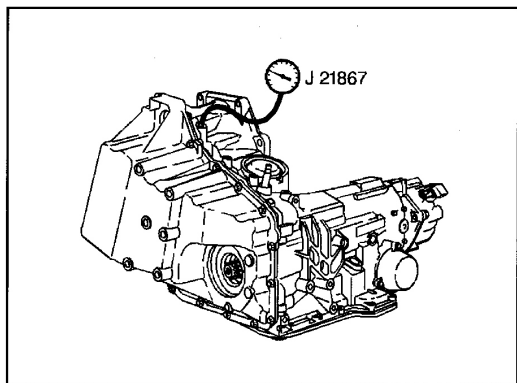

53763

7. Turn the engine OFF. Remove the oil pressure test hole plug and install the J 21867.
8. Put the gear selector in PARK range and set the parking brake.
9. Start the engine and allow the engine to warm up at idle.

Notice: Total test running time should not be longer than two minutes, or else transmission damage could occur.

10. Access the PC solenoid valve control test on the Scan Tool.
11. Increase the PC solenoid actual current from 0.0 to 1.0 amps in 0.1 amp increments. Allow the pressure to stabilize for five seconds after each pressure change. Read the corresponding line pressure on the J 21867.

G00137555

12. Refer to the Line Pressure specification table. Compare the data to the table.
13. If pressure readings differ greatly from the table, refer to Incorrect Line Pressure.
14. Remove the J 21867.
15. Apply sealant, P/N 12345382 (in Canada, P/N 10953489), to the oil pressure test hole plug.

Notice: Refer to Fastener Notice in Cautions and Notices.

16. Install the oil pressure test hole plug.

Tighten

Tighten the oil pressure test hole plug to 12 N·m (106 lb in).

Pressure Control Solenoid

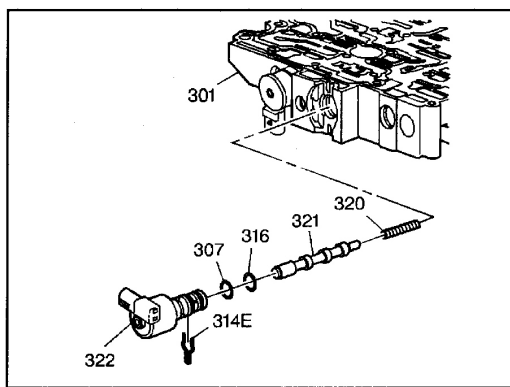

49378

Parts Information

Part Number	Description
10478146	Pressure Control Solenoid – Valve Asm.

Parts are currently available from GMSPO.

Warranty Information

For vehicles repaired under warranty, use:

Labor Operation	Description	Labor Time
K6353	Pressure Control Solenoid Replacement	Use published labor operation time
K6560	Valve Body Replacement	Use published labor operation time

Fig. 3: Page 3 of Bulletin